

Using Solid-Oxide Fuel Cells For Distributed Generation

By **Robert Zogg, P.E.**, Member ASHRAE; **Suresh Sriramulu, Ph.D.**; **Eric Carlson;**
Kurt Roth, Ph.D., Associate Member ASHRAE; and **James Brodrick, Ph.D.**, Member ASHRAE

When used in distributed generation (DG) applications, fuel cells have the potential to save energy and reduce emissions. Their inherent fuel-flexibility also could help address energy shortage issues through energy diversity.^{1,2} In addition, fuel cells have the potential to be quieter, more reliable, and have lower maintenance costs than most technologies used for DG.

This is the second in a series of articles on fuel cells for DG applications. This article addresses solid-oxide fuel cells (SOFC). An article in last month's issue addressed polymer electrolyte membrane (PEM) fuel cells.³

SOFC Characteristics and Development Status

At the heart of the power system is the SOFCs stack that generates the electrical power. SOFCs operate at high temperatures, typically 750°C to 1000°C (1,400°F to 1,800°F), although some developers are working on material systems that may operate down to 600°C (1,100°F). At these temperatures, ceramic oxide oxygen ion conductors can be used in conjunction with oxide cathodes and ceramic/metal (cermet) anodes. SOFC designs can use the electrolyte, the cathode, or the anode to provide structural support for the cell and various cell geometries such as tubular and planar. Tubular cells are formed into stacks using "tube sheets" to support the tubes. The key advantages of the tubular geometry are:

- Robustness. They are less prone to mechanical damage caused by thermally induced stresses; and
- Simpler sealing. The fuel-cell stacks (i.e., assemblies of cells) can be configured to eliminate or reduce the need for high-temperature, compliant seals.

In planar geometries, thin plate cells are sandwiched between metal interconnect plates to form stacks. The separator plates provide flow passages for the reactants and electrical conduction paths. The key advantages of the planar geometry are:

- Compactness. They have potentially higher power densities (due to lower ohmic resistance), which reduces

material content and permits compact stack configurations; and

- Lower cost. They can operate at lower temperatures (700°C to 800°C [1,300°F to 1,500°F]), permitting the use of lower-cost metal interconnect materials and lower-cost balance-of-plant materials.

Most current development programs focus on planar geometries because of their potential to achieve lower stack and balance-of-plant costs relative to tubular configurations.⁴

In addition to the stack of cells, various balance-of-plant components such as heat exchangers and pumps are required for fuel processing, managing the fluid flows and heat transfer in the system.

For most SOFCs, hydrocarbon fuels have to be processed, i.e., converted to hydrogen, before being fed to the fuel cell system. Fuel processing for SOFCs is simpler than for lower-temperature fuel cells, such as PEM fuel cells, because SOFCs are not poisoned by trace levels of CO. This enables simplification of the fuel processor design. In addition, developers are leveraging the combination of high temperature and availability of water at the anode (both unique characteristics of SOFCs) to design electrodes that contribute to fuel processing—allowing some or all of the fuel processing to take place in the stack. As with other fuel cells, SOFC anodes are poisoned by sulfur.

SOFCs can be configured to operate as simple cycles (*Figure 1*) or, when higher electric generation efficiencies are desired, hybrid cycles (*Figure 2*).^{5,6} In this example, the SOFC hybrid system incorporates a gas turbine to provide:

- Additional electric power;
- Shaft power to boost stack pressure (to about 300 kPa [3 atm]) and improve power density (thereby lowering stack size and cost); and
- Additional preheating of reactants entering the stack by recovering turbine-exhaust heat.

The relatively hot exhaust stream (typically 270°C [520°F] for simple-cycle SOFC and 190°C [370°F] for hybrid-cycle

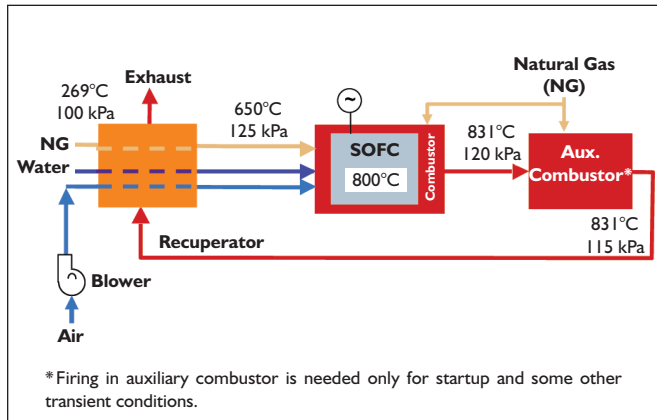

Figure 1: Simple-cycle solid-oxide fuel cell (SOFC) system.

SOFC)⁵ facilitates effective heat recovery for combined heat and power (CHP) systems, especially if the recovered heat drives an absorption cooling system.

For more details on SOFCs and other fuel-cell technologies, see the *Fuel Cell Handbook*.⁷

The development of commercially viable SOFCs based on the planar architecture will take at least another 5–7 years.⁴ The U.S. Department of Energy's Solid-State Energy Conversion Alliance (SECA) program supports development of modular (3 to 10 kW) SOFCs that also can be used in larger (more than 100 kW) DG systems.⁸ With growing concerns about energy security, SECA has expanded several of its projects to support the U.S. Department of Energy's Future-Gen initiative to demonstrate a high-efficiency, coal-fired, large-scale central power plant with CO₂ sequestration and hydrogen production.

SOFC Energy and Emissions Considerations

Two key strengths of SOFC are its high electric generation efficiencies (both at full and part load), and its ability to operate above its rated capacity (at somewhat reduced efficiencies). For large (megawatt scale) systems, representative full-load efficiencies are 50% (HHV) (55% [LHV]) for simple cycles and 60% (HHV) (65% [LHV]) for hybrid cycles (Figure 3).⁵ One study projects that seasonal primary energy savings for large SOFC DG systems serving a mixed residential, commercial, and industrial community will be in the range of 35% to 45% compared to the national average utility grid.⁵ Use of CHP will result in even greater energy savings.

Smaller simple-cycle systems (3 to 10 kW) will likely have lower efficiencies—roughly 30% to 40% (HHV) (35% to 45% [LHV]).⁴ Smaller systems' efficiencies are lower than those for the larger-capacity systems because the parasitic losses account for a greater fraction of the total power output. This

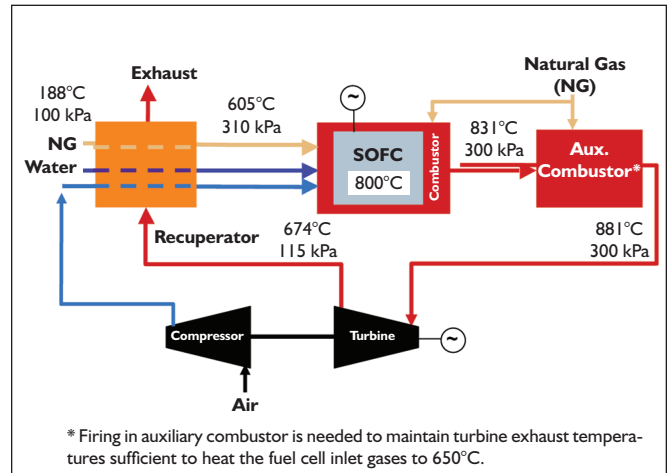

Figure 2: Solid-oxide fuel cell/gas-turbine hybrid system.

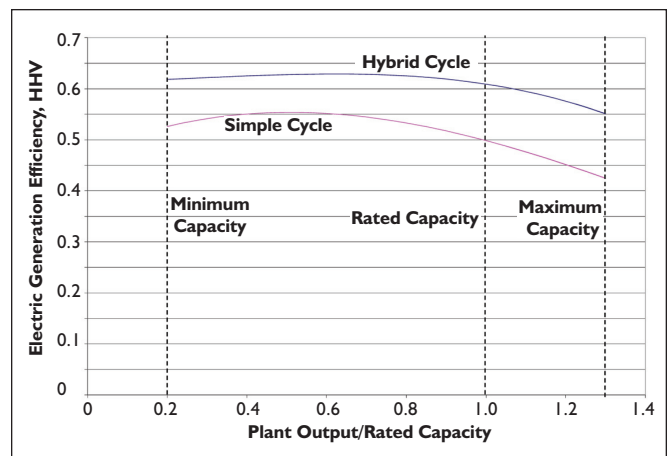

Figure 3: Efficiency curves for large-scale SOFC DG systems.

efficiency range can still provide primary energy savings relative to the grid, especially if used in CHP applications.

Projections indicate that emissions reductions will be even more dramatic, with roughly order-of-magnitude reductions in both SO₂ and NO_x emissions compared to the current national-average generation mix.⁵

SOFC Cost Challenges

As with all fuel-cell technologies, achieving SOFC costs consistent with market requirements for DG and CHP applications will be challenging. The SECA program has targeted factory costs of \$400/kW by 2010. Installed costs will likely be two to three times higher. These cost targets assume successful market introduction with high production volumes (roughly 500,000 units/year by a single manufacturer). As with many emerging technologies, a key commercialization chal-

challenge is to identify high-value applications that can support early market growth in spite of higher costs. Early candidate markets include auxiliary power units for military, trucking, and marine applications.

Promising DG Applications for SOFC

If ongoing development programs succeed, SOFC's high generation efficiencies, low emissions, quiet operation, and high-temperature reject heat will make it attractive for a range of DG and CHP applications, providing stiff competition for the currently preferred DG technology, the internal combustion engine. In particular, SOFC's high generation efficiencies will improve the economics of DG and CHP in applications that don't have:

- a) large, steady thermal loads (i.e., the bulk of commercial buildings), or
- b) net metering policies for fossil-fuel-fired generation technologies.

References

1. Zogg, R., K. Roth, and J. Brodrick. 2005. "Using CHP systems in commercial buildings." *ASHRAE Journal* 47(9):33–35.
2. Zogg, R., K. Roth, and J. Brodrick. 2005. "Combined heat and power for residences." *ASHRAE Journal* 47(7):142–143.
3. Lasher, S., et al. 2006. "PEM fuel cells for distributed generation." *ASHRAE Journal* 48(11):45–48.
4. TIAX. 2005. "Technology Review and Assessment of Distributed Energy Resources: Distributed Generation." Prepared for the Electric Power Research Institute (EPRI). Product ID 053828.
5. TIAX. 2004. "An Assessment of a Hydrogen Cities Concept Applied to a Representative Community." Prepared for the U.S. Department of Energy, National Energy Technology Laboratory, Solid-State Energy Conversion Alliance. <http://tinyurl.com/y6evee>.
6. TIAX. 2003. "Scale-Up of Planar SOFC Stack Technology for MW-Level Combined Cycle System." Prepared for the U.S. Department of Energy, National Energy Technology Laboratory, Solid-State Energy Conversion Alliance. <http://tinyurl.com/y6evee>.
7. EG&G Technical Services. 2004. *Fuel Cell Handbook (Seventh Edition)*. <http://tinyurl.com/y6evee>.
8. SECA Web site. <http://tinyurl.com/wup6j>.

Robert Zogg, P.E., and Kurt Roth, Ph.D., are associate principals with TIAX, LLC, Cambridge, Mass. Suresh Sriramulu, Ph.D., and Eric Carlson are principals with TIAX. James Brodrick, Ph.D., is a project manager in the Building Technologies Program, U.S. Department of Energy, Washington, D.C. ●

Advertisement formerly in this space.